

Mark Scheme

Principal Learning

Sample Assessment Material Information Technology IT307 Making Projects Successful Level 3 Unit 7

General Marking Guidance

- All candidates must receive the same treatment. Examiners must mark the first candidate in exactly the same way as they mark the last.
- Mark schemes should be applied positively. Candidates must be rewarded for what they have shown they can do rather than penalised for omissions.
- Examiners should mark according to the mark scheme not according to their perception of where the grade boundaries may lie.
- There is no ceiling on achievement. All marks on the mark scheme should be used appropriately.
- All the marks on the mark scheme are designed to be awarded. Examiners should always award full marks if deserved, i.e. if the answer matches the mark scheme. Examiners should also be prepared to award zero marks if the candidate's response is not worthy of credit according to the mark scheme.
- Where some judgement is required, mark schemes will provide the principles by which marks will be awarded and exemplification may be limited.
- When examiners are in doubt regarding the application of the mark scheme to a candidate's response, the team leader must be consulted.
- Crossed out work should be marked UNLESS the candidate has replaced it with an alternative response.

Question Number	Answer	Mark
1(a)	<p>Any two of:</p> <ul style="list-style-type: none"> • EPOS terminals • Detailed sales analysis • Real time stock control • Customer information 	(2)

Question Number	Answer	Mark
1(b)	<p>First mark for identifying reason, second mark for the associated expansion. Maximum of two marks for each stakeholder.</p> <p><u>The Owners</u> Increase revenue: more efficient stock control, faster throughput at terminal, better targeting of customers, reduces fraud Improve image of the park: using current technology, improved customer experience, encourages customers to return, less scope of errors from manual processing</p> <p><u>MT Surfaces</u> Professional reputation: show they can do a good job on time, can use to pitch for future contracts</p> <p><u>LMY Bank</u> Make money: using their investment to create more income for shareholders</p>	(6)

Question Number	Answer	Mark
1(c)	<p>Any two of:</p> <ul style="list-style-type: none"> • Project completed by 31st January • All objectives met • Work completed to specification • Project completed within budget 	(2)

Question Number	Answer	Mark
2(a)	<p>First mark for identifying aspect, second mark for the associated expansion.</p> <ul style="list-style-type: none"> • Create plan: breakdown tasks, estimate timescales, define dependencies, critical path • Plan resources: equipment, labour, money, timing • Costs/Finance: budget, contingency fund, availability of finance • Quality assurance: Specify standards required (client/legal) • Acceptance testing: setting the parameters for acceptance, what it will entail • Communication with stakeholders: when/how • Project review: who carries them out/when • Reporting: when/who to/method 	(4)

Question Number	Answer	Mark
2(b)	<p>First mark for identifying feature, second mark for the associated expansion.</p> <ul style="list-style-type: none"> • Different views: use different visual representation to suit needs, creates charts and diagrams • Range of automatic update features: if time allocated to a task is changed all subsequent timings update • Compatibility with other application software: can export data into different software, transfer data electronically • Facilities for tracking: allocate task resources, record task percentage complete • Baseline plan: baseline provides reference points to compare actual project progress, can modify/rework the baseline at any time during the project if the scope or nature of the project has changed • Any other suitable feature: suitable expansion 	(6)

Question Number	Answer	Mark
3	<p>First mark for identifying factor, second mark for the associated expansion.</p> <ul style="list-style-type: none"> • All stakeholders must have a clear understanding of the project objectives: so that they are all working together to a common goal, clear communication, good teamwork • Must have a realistic bidding process at outset: so that all costs are accurately identified • Must keep within budget during the project: overspend could result in job not being finished • Effective planning: so that the right resources are available at the right time • Accurate risk assessments or build in contingency time: to allow for the unexpected 	(4)

Question Number	Answer	Mark
4(a)	<p>Any four of:</p> <ul style="list-style-type: none"> • Summary headings • Milestone dates • Start dates • Finish dates • Task ID • Task name • Duration of tasks • Duration of each stage • Project completion date 	(4)

Question Number	Answer	Mark
-----------------	--------	------

4(b) 1 mark for each correct figure calculated / identified.

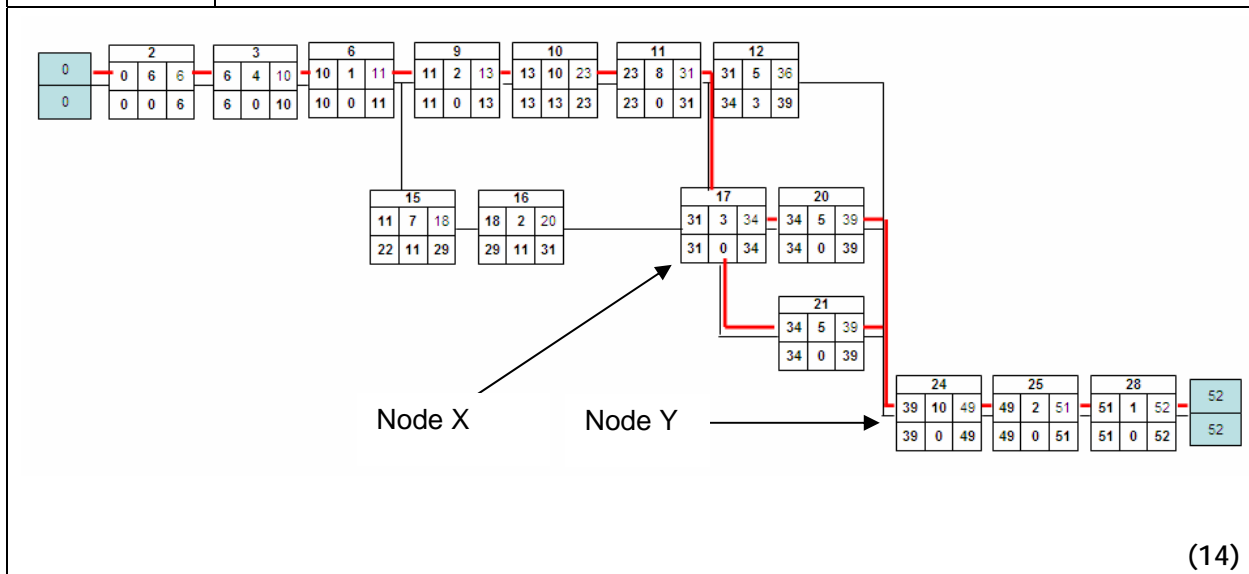

Question Number	Answer
5(a)	<p>Key Points:</p> <ul style="list-style-type: none"> • To make sure that the digging is completed on time • To prevent the start of the next task being delayed (laying and connecting cables) • To avoid the consequences of a knock on effect to subsequent tasks on the critical path • A delay at this stage could escalate to delay a critical task • To ensure that the park is ready to open on March 1st • Small costs relative to the losses that would result from not opening on time • Consequences of not opening on time e.g. Bad publicity, loss of business, unhappy staff, dissatisfied customers
Mark	Descriptor
0	No relevant information
1-2	Candidates produce an unstructured response, showing little if any understanding of the wider implications of a delay.
3-4	Candidates attempt to produce a structured response that demonstrates some understanding of the wider implications of a delay.
5-6	Candidates produce a structured, well thought out response and clearly demonstrate a good understanding of the overall consequences of a delay.

Question Number	Answer	Mark
5(b)	<p>First mark for benefit, second mark for an associated expansion.</p> <ul style="list-style-type: none"> • Changes in government policy: e.g. change in VAT leading to overall change in cost, Changes to Health & Safety legislation affects working conditions • Rise/fall in interest rates: will effect budget • Resources problems: e.g. equipment breaks down, staff off ill, Industrial action, late or non deliverable of supplies • Discovery of archaeological artefacts whilst digging: project will be put on hold whilst being investigated 	(4)

Question Number	Answer	Mark
6	<p>First mark for identifying function, second mark for the associated expansion.</p> <ul style="list-style-type: none"> • To check progress against plan: adjusting timings and/or resources as necessary, updates from contractors, checking milestones have been achieved • To review risks: flag up potential problems and identify solutions • To review next stage of activities: to ensure everyone knows what happens next and create positive momentum amongst stakeholders • To monitor expenditure: to ensure project is still within budget, take steps to procure more money or identify cost cutting measures if necessary 	(4)

Question Number	Answer	Mark
7	<p>First mark for identifying task, second mark for the associated expansion.</p> <ul style="list-style-type: none"> • Production of end of project review report for the client: to document the project, identify strengths and weaknesses, listing contacts, review the success of the project • Formal handover to client: finalisation of any contracted services, handover of all documents e.g. warranties, guarantees, training manuals • Celebration of project completion: with the project team and stakeholders 	(4)

Question Number	Answer	Mark
8(a)	<p>One mark for each objective identified.</p> <ul style="list-style-type: none"> • To change the method by which car insurance is calculated • To enable motorists to be charged insurance based upon their actual car usage • To use data such as time of day, distance, routes travelled 	(3)

Question Number	Answer	Mark
8(b)	<p>First mark for identifying task, second mark for the associated expansion.</p> <ul style="list-style-type: none"> • Increased sales: by extending product range, introducing insurance to meet customer needs, attracting young drivers • Decreasing outgoings / reduce number of insurance pay outs: by making driving at high risk times unattractive • Positive company image: being seen as to offering innovative, technology based solutions, helping to reduce road traffic accidents/traffic congestion 	(6)

Question Number	Answer
9	<p>Key Points:</p> <ul style="list-style-type: none"> • Research <ul style="list-style-type: none"> - Identified customers who would prefer their motor insurance to be calculated according their car usage - Began developing a system that could record movement of cars by time , distance and routes - Use of relevant data used to charge customers • Proof of Concept <ul style="list-style-type: none"> - Tested technology in laboratory conditions - Issued 20 staff with devices after successful tests • Pilot 1 <ul style="list-style-type: none"> - Recruited participants from customer base - 500 users (out of 5000) us to collect store and analysis data, over a four month period - Identified early issues, e.g. services, logistics of installation • Pilot 2 <ul style="list-style-type: none"> - Rolled out to remaining 4500 users - Data used for insurance premium analysis - Identified data capacity issues • Testing <ul style="list-style-type: none"> - Carried out live trial - Analysed user acceptance
Mark	Descriptor
0	No relevant information
1-3	<p>Candidates produce an unstructured response, showing little if any understanding of the Norwich Union project</p> <p>Information may be a list of some key points with no or little relevance to Norwich Union, or simple descriptions of generic project stages or tasks</p>
4-6	<p>Candidates attempt to produce a structured response that demonstrates some understanding of the Norwich Union project</p> <p>May include some the key stages in the Norwich Union Project with some of the associated activities</p>
7-9	<p>Candidates produce a structured, well thought out response and clearly demonstrate a good understanding of Norwich Union Project</p> <p>Includes most of the key stages with the associated activities in the Norwich Union Project</p>

Question Number	Answer
10	<p>Key Points:</p> <ul style="list-style-type: none"> • Each phase was evaluated on its own merits before moving to the next phase • Issues raised from each evaluation stage were resolved before moving to the next stage • Proof of concept carried out by Norwich Union staff to avoid adverse publicity from arising technical issues • Pilot 1 carried out to small test group to identify and resolve issues before piloting with majority, minimising operational problem • Stress tested IT infrastructure to minimise technical / software problems • Testing carried out with a clearly identified market audience to ensure product met customers needs
Mark	Descriptor
0	No relevant information
1-4	Candidates produce an unstructured response, showing little if any understanding of how the strategies used led to the success of the project
5-7	Candidates attempt to produce a structured response that demonstrates some understanding of how the strategies used led to the success of the project
8-12	Candidates produce a structured, well thought out response and clearly demonstrate a good understanding of the strategies used and how these led to the success of the project